

| [About Us](#) || [Security](#) || [Products](#) || [Contact](#) || [Services](#) |

### [Advantages of using Parnassus](#)

## *Airline Software*

Statistical database applications development, with emphasis in aerospace reliability, and quality systems.  
[ [More information](#) ]



Networkable PC based quality assurance software application  
[ [More information](#) ]



Collecting and analyzing removal and maintenance history of the aircraft components  
[ [More information](#) ]

# Engineering for Aerospace.

Parnassus provides reliability engineering services to the aerospace industry. We also design software products to various business units requiring state of the art, turn-key database applications programs.

Since 1979 Parnassus has established a niche market by measuring the reliability performance of aircraft components. These products have been installed on aircrafts operated by commercial airlines worldwide. During the last 23 years Parnassus has worked with component manufacturers and aircraft operators to help improve the airline industry's reliability and profitability. This experience allows us to provide aircraft system / component reliability and failure mode analyses based on actual performance as well as traditional analytical methods.

Parnassus reliability engineering group specializes in system safety assessments based on the guidelines of SAE ARP4761 that have achieved type certification status for various hydraulic, electromechanical and hardware/software systems. These products are used on aircraft manufactured by Airbus, BHTC, Boeing, CASA and Cessna.

Parnassus software group specializes in the development

## System Safety Analyses

Comprehensive evaluation of your equipment  
[ [More information](#) ]

## Failure Modes and Effects Analysis

Systematic, bottom-up way of identifying the failure modes of a system, item or function  
[ [More information](#) ]

## Failure Rate Predictions

Determining piece part level failure rates in aerospace equipment  
[ [More information](#) ]

## Reliability Safety

Parnassus offers many services to help keep you up to standards  
[ [More information](#) ]

free community ads  
[ [your add here](#) ]  
e-mail us for details

of user specific database applications. These applications deal largely with manufacturing quality assurance and the documentation of detailed repair and overhaul (depot level maintenance) records. The focus of these products is in the acquisition and analysis of reliability specific statistics.

## **In the news:**



**Parnassus** launches new web site february of 2002. All new flash tours and walk thourghs are becoming avalible for viewing during this time of change and renewal of Parnassus. More informative pages to help the aerospace industry are now avalible. Please enjoy all the changes and additions to our web site. Look for more new articles and informaiton on our site next month.

| [About Us](#) | [Security](#) | [Products](#) |  
[Contact](#) | [Services](#) |

[Advantages of using Parnassus](#)



Statistical database applications development, with emphasis in aerospace reliability, and quality systems. [[More information](#)]



Networkable PC based quality assurance software application [[More information](#)]



Collecting and analyzing removal and maintenance history of the aircraft components [[More information](#)]

# History of Parnassus

For all our customers, I want so say thank you for your support. This is a look at our new website. We have made some changes in the layout and the services. Please take a look at our site and let us know what you think. For all who are not familer with us let me introduce myself.

Hello, my name is Al Depew. I am the owner of a reliability consulting company called Parnassus. We've been in business since 1979, in fact I started the company. Throughout the years we've subcontracted both on-site and off-site reliability & systems safety services from a small group of about a dozen aerospace companies. A list of these companies are on the Contact History page. References are available upon request.

The experience we've acquired includes avionics systems and integrated engine and instrument displays, air data systems, communications & navigation equipment, various hydraulic pumps, motor pumps and actuators, mechanical assemblies and electro-mechanical systems including cargo-bay loading / unloading control systems for 747's etc. We maintain a company focus of furthering the operating cost effectiveness, safety and reliability of all

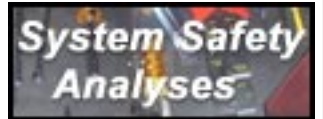

Comprehensive evaluation of your equipment [[More information](#)]

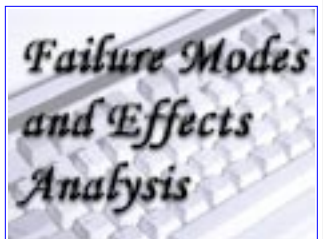

Systematic, bottom-up way of identifying the failure modes of a system, item or function [[More information](#)]

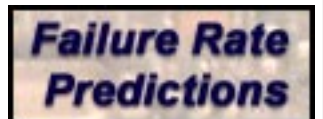

Determining piece part level failure rates in aerospace equipment [[More information](#)]



Parnassus offers many services to help keep you up to standards [[More information](#)]

free community ads [[your add here](#)] e-mail us for details

aircraft components, especially commercial aerospace systems.

Parnassus is a small independent consulting company, so we tend to keep fairly busy year-round. We make a policy of not overbooking ourselves at the expense of any client. We do schedule work in-advance however, if you would be interested in discussing possible services in the near term.

Though we perform about 40% of our services on-site, we differ from a job-shop in more than a couple of ways. First we don't place engineers on-site with whom we have not previously worked side-by-side, and I personally perform services directly for all of our clientele. Our charter is more focused on customer satisfaction in the quality of engineering services provided than it is on the cumulative hours we bill each month, i.e. we're not a "body-shop" by any stretch of the imagination. Second, the majority of our work being for repeat customers, is performed in-house at Parnassus' facilities. Experience has shown, however, that most new clients prefer to see us in action on-site on the first job, and that holds a benefit to us as well by allowing us to get acquainted first-hand with the engineering personnel we intend to support for years to come.

Again, thank you sincerely for your interest in Parnassus. We would be very happy to discuss the possibilities of becoming a reliable out-source for your technical services overflow. For more on our company go to our website at [Parnassus.org](http://Parnassus.org). Should you have any questions or require additional information please feel free to call or email.

Best regards,

Alana Depew  
(President Parnassus)

| [About Us](#) | [Security](#) | [Products](#) |  
[Contact](#) | [Services](#) |

| [About Us](#) || [Security](#) || [Products](#) || [Contact](#) || [Services](#) |

Statistical database applications development, with emphasis in aerospace reliability, and quality systems.

[ [More information](#) ]



Collecting and analyzing removal and maintenance history of the aircraft components

[ [More information](#) ]

## Security for client information.

All client information is kept completely confidential. We do offer nondisclosure agreements for those clients who would like a written contract of confidentiality. Information regarding our clients is kept in the hands of the Parnassus representative to our clients and the engineer working on the project only. No other employees of Parnassus have access to projects that they are not personally working on.

Parnassus is currently switching over from standard network/Internet security. During the months of February and March of 2002 we are converting to a Unix servers with open BSD interface. Open BSD Unix is well known as the most secure sever operating system. We are also using opensource software to implement firewalls and intrusion detection software. This will help insure that our clients data is safe in our hands and on our computers.

| [About Us](#) | [Security](#) | [Products](#) |  
[Contact](#) | [Services](#) |

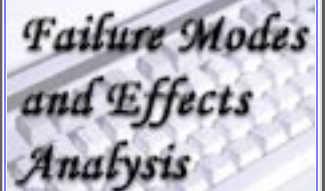

Systematic, bottom-up way of identifying the failure modes of a system, item or function

[ [More information](#) ]



Determining piece part level failure rates in aerospace equipment

[ [More information](#) ]

| [About Us](#) | | [Security](#) | | [Products](#) | | [Contact](#) | | [Services](#) |

[Advantages of using Parnassus](#)



Proper acquisition and analysis of in-field performance and maintenance data  
[ [More information](#) ]



Collecting and analyzing removal and maintenance history of the aircraft components  
[ [More information](#) ]

# Parnassus Software products.

Parnassus specializes in statistical database applications development, with emphasis in aerospace reliability, and quality systems. Below two of our recent software packages are described in brief. If your interest is peaked by either of these Windows applications, click the logo for more info.



The

Reliable Reliability Software for aircraft operators, overhaul & maintenance facilities and component OEMs world-wide. ALS' graphical, point 'n click operation (bar-code also available) is the fastest, most accurate way to acquire piece-part level maintenance information. For more information about any of our ALS software tools, please click here.



Sample Lot

Inspection (SLI) database is a network able, PC-based Quality

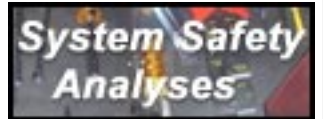

Comprehensive evaluation of your equipment  
[ [More information](#) ]

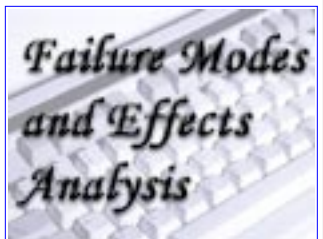

Systematic, bottom-up way of identifying the failure modes of a system, item or function  
[ [More information](#) ]



Parnassus offers many services to help keep you up to standards  
[ [More information](#) ]

free community ads  
[ [your add here](#) ]  
e-mail us for details

Assurance software application for Incoming Inspection and Material Review Board (MRB) departments. SLI's premier feature is the ease and flexibility with which it can be configured to accommodate any Sample Lot methodology.

| [About Us](#) | [Security](#) | [Products](#) |  
[Contact](#) | [Services](#) |

| [About Us](#) | | [Security](#) | | [Products](#) | | [Contact](#) | | [Services](#) |

[Advantages of using Parnassus](#)



Networkable PC based quality assurance software application  
[ [More information](#) ]



Collecting and analyzing removal and maintenance history of the aircraft components  
[ [More information](#) ]

# Getting in touch with Parnassus.

Thank you sincerely for your interest in Parnassus. We would be very happy to discuss our customer support. Should you have any questions or require additional information please feel free to call or email.

Best regards,

Alana Depew  
( Parnassus President )

Telephone: (805)-552-9552  
( Voice Mail is available on this number 24/7 )

Fax: (805)-552-9553

E-mail:  
[parnassu@ix.netcom.com](mailto:parnassu@ix.netcom.com)

| [About Us](#) | [Security](#) | [Products](#) |  
[Contact](#) | [Services](#) |

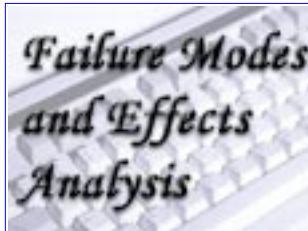

Systematic, bottom-up way of identifying the failure modes of a system, item or function  
[ [More information](#) ]



Parnassus offers many services to help keep you up to standards  
[ [More information](#) ]

free community ads  
[ [your add here](#) ]  
e-mail us for details

[| About Us |](#) [| Security |](#) [| Products |](#) [| Contact |](#) [| Services |](#)

[Advantages of using Parnassus](#)



Statistical database applications development, with emphasis in aerospace reliability, and quality systems. [[More information](#)]



Networkable PC based quality assurance software application [[More information](#)]

# Services offered by Parnassus.

**Reliability & System Safety Services:**

On-Aircraft Data Acquisition

Independent **Discussions:**

- 3rd Party Audits & Reports [Article 1](#)
- [Article 2](#)
- [Article 3](#)

Failure Rate Predictions

Modeling and Allocations

Failure Modes and Effects Analysis

System Safety Analyses

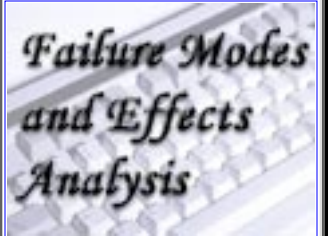

Systematic, bottom-up way of identifying the failure modes of a system, item or function [[More information](#)]

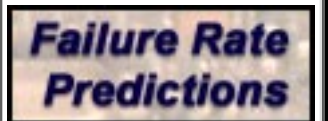

Determining piece part level failure rates in aerospace equipment [[More information](#)]



[[More information](#)]

[| About Us |](#) [| Security |](#) [| Products |](#) [| Contact |](#) [| Services |](#)

| [About Us](#) || [Security](#) || [Products](#) || [Contact](#) || [Services](#) |

## Advantages of using Parnassus .



Networkable PC based quality assurance software application

[ [More information](#) ]



Collecting and analyzing removal and maintenance history of the aircraft components

[ [More information](#) ]

Parnassus is a client oriented company.

Clients are always treated to fast and effective help by our staff. Our engineers are available monday-friday 9am to 5pm for any question our clients may have regarding there projects.

Another important benifit is that our engineers get the job right the first time. Our clients get less headaches by having engineers layout the project with them so the job is done right the first time. Our clients are also assured that if there not completely happy with our service, we will do up to two free revisions of their project as long as the clients project hasn't changed in a different scope.

Our clients get fast reliable and experianced help with Parnassus. Client information is never left unprotected to cyber criminals. Our internet security is top of the line with no exceptions. Our reports are easy to understand and can be issue to our clients in two different packages. One for engineers and the other for the office staff. For more information please call us at (805) 552-9552.

### System Safety Analyses

Comprehensive evaluation of your equipment

[ [More information](#) ]

### Failure Rate Predictions

Determining piece part level failure rates in aerospace equipment

[ [More information](#) ]

### Reliability Safety

Parnassus offers many services to help keep you up to standards

[ [More information](#) ]

| [About Us](#) | [Security](#) | [Products](#) |  
[Contact](#) | [Services](#) |



SLI is a flexible, secure, ODBC database application used to administrate and record Sample Lot Inspection acceptance, rejection(s) and Material Review Board (MRB) activity and disposition.

All Incoming material, part and process lot history are recorded in a manner that makes ... QE a snap.

### Program Features:

- Quick-Lookup feature lets Inspectors determine if an incoming lot must be Inspected or Skipped.
- If your system includes 1st Article requirements, SLI checks the database for existing part number and revision records and automatically notifies Inspectors when required.
- Open Database Connectivity (ODBC) allows real-time Quality Engineering analyses without system or personnel interruptions.
- Designed for and used by major equipment manufacturers running under Windows 95 & WindowsNT.
- Simplified user interface reduces training requirements for Inspectors and minimises IS requirements for System Administrators

### Flexibility and Functionality:

- Extensive System Administration features allow you to setup SLI for the Sample Lot criteria you need, i.e. variable inspection level, inspection and skip-lot cycles, component / material / process types, certified vendors, data fields required or optional by your system, 1st Article required / optional, simplified user name - password - privilege edit, database record maintenance, etc.
- "But what if my criteria changes or I want to modify it for some reason?" Changes to SLI's configuration are incorporated *on the fly* commencing with the next incoming product lot.
- Top-down, modular design and a proven, robust database have demonstrated functionality in high volume industrial use. Email us for references.

### Benefits of using SLI:

- Automated Sample Lot Inspect or Skip decision
- Increased Inspection and MRB efficiency
- Database availability to support Quality Engineering analyses and reporting
- ODBC allows network utilization of existing MIS systems to better automate administrative tasks.

### Take the Tour:

*... a slide-show demonstration*

### Purchase Options:

*... evaluation, standard purchase & site licences, email us.*



# Welcome to the SLI Pic-Tour

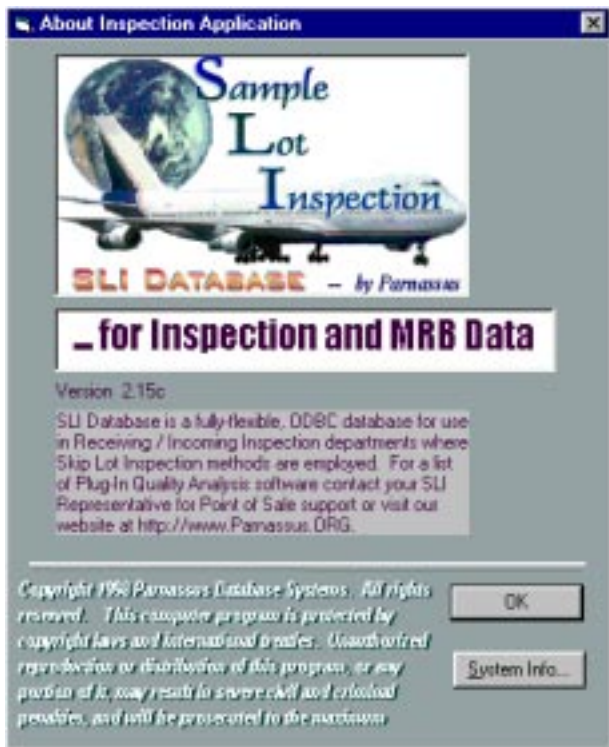

*For browsing speed, we've reduced the size of SLI's operator screens that are displayed on these pages. For your enjoyment and to reduce unnecessary eye-strain, clicking on any of these graphics top display a full-size view of the screen.*

*As mentioned earlier, SLI is a relational database system designed to automate the Sample Lot Inspection decision process and record all pertinent Incoming Inspection and Material Review Board (MRB) data. Plug-ins to SLI are available from Parnassus to quantify various indices of Quality Engineering.*

*SLI was commissioned by an aerospace and automotive manufacturing company and developed by Parnassus.*

Click [HERE](#) to proceed.

# Quick Lookup

For speed any user can perform a Quick Lookup, by clicking the "Run Lookup" button in the upper left of the screen, and immediately determine what level of inspection the part number and revision is at and if Inspection is required or not.

There is NO LOGON required to perform this task and no data is posted to the database. It is simply a time saving tool to facilitate the flow of material through Incoming Inspection.

SLI posts the Quick Lookup form on top of the Main Screen (shown to the right of the main form, above).

The information required to run Quick Lookup consists of:

- Supplier Name (from Drop-Down list) or
- Supplier Number (from Drop-Down list)
- Part Number (alphanumeric)
- Revision letter and
- Lot Number

When the "OK" button is clicked, SLI the queries the database and posts the results in the Quick Lookup frame (left of screen).

Quick Lookup can also be run after logon. If so, SLI will post the results as described above and then display the appropriate Inspect, Skip or 1st Article Inspect screen ([next](#)).

# Inspection Data Acquisition

Shown below, is the data acquisition screen for 1st Article Inspection. This is the same screen that is used for Inspection and Skip Lot data input. The "required fields" for each type of data acquisition are selectable by the System Administrator.

The screenshot shows a software interface for data acquisition. It is divided into three main sections:

- Control Box (Left):** Contains a 'Quick Lookup' section with a 'Run Lookup' button. Below it, 'Lookup Results' shows '1st Article'. There is an 'Insp. History' section with '1st Article Status' and three input fields for 'Level', 'Pass #', and 'Skips #'. At the bottom are 'Logoff' and 'Exit' buttons.
- Paperwork, Supplier and Part Data (Middle):** This is the main data entry area. It contains:
  - Paperwork Info:** Job Number, P.O. Number, and Shipper Number, all with the value '123456789ABCDEFG'.
  - Supplier Info:** Name (ACE) and Number (12345). Below are radio buttons for 'Part', 'PL Part', 'Certified', 'Process', and 'Raw Material'.
  - Part and Inspection Info:** Part # (12999A-068003), Rev. (A2), Lot # (290953), Lot Qty (12), and Sample Qty (12).
  - Acceptance:** Accept (10) and Reject (2) fields.
  - Rejection Data:** NR # (02300000aa) and a 'Save Record' button.
- Visual Area (Right):** Contains two images: the top one shows a factory floor with workers, and the bottom one shows a close-up of a metal spring-like part.

If any quantity of the inspected lot is rejected by the Inspector, the Reject Quantity field will be greater than zero and the non-conformance (NR) # field, shown in the lower left of the Paperwork, Supplier and Part Data Frame as used to record the rejection number. When this occurs, and the user hits the ENTER key or clicks "Save Record" the NR Table (shown in the [next page](#)) is displayed, otherwise the data is stored in the database and SLI is ready to record the next Inspection record.

# Recording Rejection Data

When the "Reject Qty" field exceeds 0 and the "NR #" is filled-in, the NR Table form (shown below) is displayed to facilitate acquisition of non-conforming record data.

The screenshot shows the 'NR Table' dialog box overlaid on the main software interface. The dialog box has a title bar that says 'NR Table' and a close button. Below the title bar, it displays 'NR #: 2382'. The main area of the dialog box contains a table with the following structure:

Item #	Quantity	Description

Below the table, there is a text box with the following text: "Enter the NR Item number, Nonconforming Quantity and a Describe the Nonconformance that resulted in rejection. MAKE SURE YOU ENTER DATA IN ALL THREE FIELDS & s. Press Enter after finishing the last Description field OR YOUR LAST ITEM # ROW (record) WILL BE LOST." At the bottom of the dialog box, there are two buttons: 'DONE' and 'CANCEL'.

The background interface shows the 'Paperwork, Supplier and Part Data' form. The 'Rejection Data' section at the bottom of the form shows 'NR #: 2382' and a 'Save Record' button.

The NR #, input in the previous frame is displayed above the table which is comprised of the following fields:

- Item # - The line item number for each specific reason for rejection (item rejected)
- Quantity - the number of items rejected for each reason
- Description - the Inspectors description of the reason for rejection.

When the fields are filled-in by the Inspector, the DONE button is clicked, the data record is stored and SLI returns to the Main form (ready for the next job).

# Material Review Board

When a person with MRB level password privilege logs on and selects the MRB option, the MRB screen is displayed. The operator then selects an "NR #" and "Item #", and the MRB screen displays the corresponding Inspection and MRB data.

Control Box	Paperwork, Supplier and Part Data	MRB and Corrective Action Data
<b>Quick Lookup</b> <input type="button" value="Run Lookup"/> <b>Lookup Results:</b> <i>1st Article</i> <b>Insp. History:</b> <b>1st Article Status:</b> Level: <input type="text"/> Pass #: <input type="text"/> Skips #: <input type="text"/> <input type="button" value="Logoff"/> <input type="button" value="Exit"/>	<b>Paperwork Info</b> Job Number: 123456789ABCDEFG P.O. Number: 123456789ABCDEFG Shipper Number: 123456789ABCDEFG <b>Supplier Info</b> Name: ACE Number: 12345 <input type="checkbox"/> Part <input checked="" type="checkbox"/> PL Part <input type="checkbox"/> Certified <input checked="" type="checkbox"/> Process <input type="checkbox"/> Raw Material <b>Part and Inspection Info</b> Part #: 12999A-068003    Rev: 52    Lot #: 290953 Lot Qty: 12    Sample Qty: 12 Accept: 10    Reject: 2 <b>Rejection Data</b> NR #: 2302 <input type="button" value="Save Record"/>	<b>MRB Data</b> <input checked="" type="checkbox"/> (Check) If Corrective Action Required Corrective Action #: 2302/2 Open Date: 7/20/99 7:21:27 AM    Closed Date: <input type="text"/> NR Code: 102-550    Disposition Code: <input type="text"/> Responsible: <input type="text"/> Defect Code: <input type="text"/> NR #: 2302    Item #: 2 Disposition: <i>Small leak noted from housing gasket</i> <input type="button" value="Save Record"/> <input type="button" value="Cancel"/>

If Corrective Action is required, the "Corrective Action" checkbox is clicked and SLI assigns a corrective action number to the record. As MRB data is determined, SLI is used to store a permanent record. At any point in the process, the operator can click the "[Save Record](#)" button to store the data.

## Reliability Engineering



Click on logo to return!

Analyzing the On Aircraft (field) reliability performance can garner a real world knowledge of both failure modes and reliability as well as a definite competitive advantage for your company's product-line.

---

### On Aircraft Performance Monitoring:

For more than 15 years, Parnassus has worked directly with major airline operators worldwide collecting and analyzing removal and maintenance history of the aircraft components our clients manufacture and provide critical support of. This experience covers avionics systems and integrated engine and instrument displays, air data systems, communications & navigation equipment, various hydraulic pumps .. motor-pumps and actuators, mechanical assemblies and electro-mechanical systems including cargo-bay loading / unloading control systems, etc.



The product of our On Aircraft performance analyses yield irrefutable support of successful product improvement design decisions and competitive marketing campaigns, e.g. cost of ownership, power by the hour, maintenance operating costs, etc. We work directly with airline maintenance depots and your customer support organizations world-wide to target, acquire and track the LRU, SRU and piece part level maintenance histories of your equipment and systems.

Depending on the product, our analysis reports have been responsible for determining the outcome of numerous call-outs and retrofit electives by a host of aircraft operators. And they've provided the basis for determining the weak links in many equipment designs. If you'd like to know more about how Parnassus can help you acquire and analyze the performance of your aircraft components, please inquire.

to learn more about on-aircraft performance monitoring services please call or email.

# ALS

## Program Description



Airline Software (ALS) is a graphical database system used to record Flight Line and Depot level maintenance actions on specific aircraft components. Data acquisition (input) begins (i.e. a new database record is opened) when, on the flight line, an equipment (component) is removed from an aircraft for any reason. Later, the record is accessed by at the Depot during Findings (bench test) and maintenance (Action Taken), and all parts repaired and replaced, shop labor, mod records, etc. are input using ALS's unprecedented graphical to database interface.

By applying the benefits & convenience of an on-line database with consistently detailed, explicit maintenance data, airline operators are finally able to attain precise information on maintenance costs, piece part consumption rates, removal reasons @ unit hours (for hard / soft timing), etc. ALS includes seven (7) standard reports for your convenience and also exports data for use by your Component and Fleet engineers.

Program Description - Navigation bar



to learn more about the features of ALS or other products please email

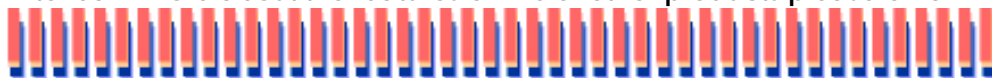

# ALS Data Input (Line & Depot)

The overwhelming benefits to speed, accuracy and repeatability of maintenance data / documentation garnered by using ALS derive the genesis in the design concept of the data acquisition modules. ALS Point & Click component modules (unique for each component type) are created from detailed exploded view drawings and piece part data published in OEM component maintenance manuals (CMM).

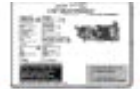

Sample Form

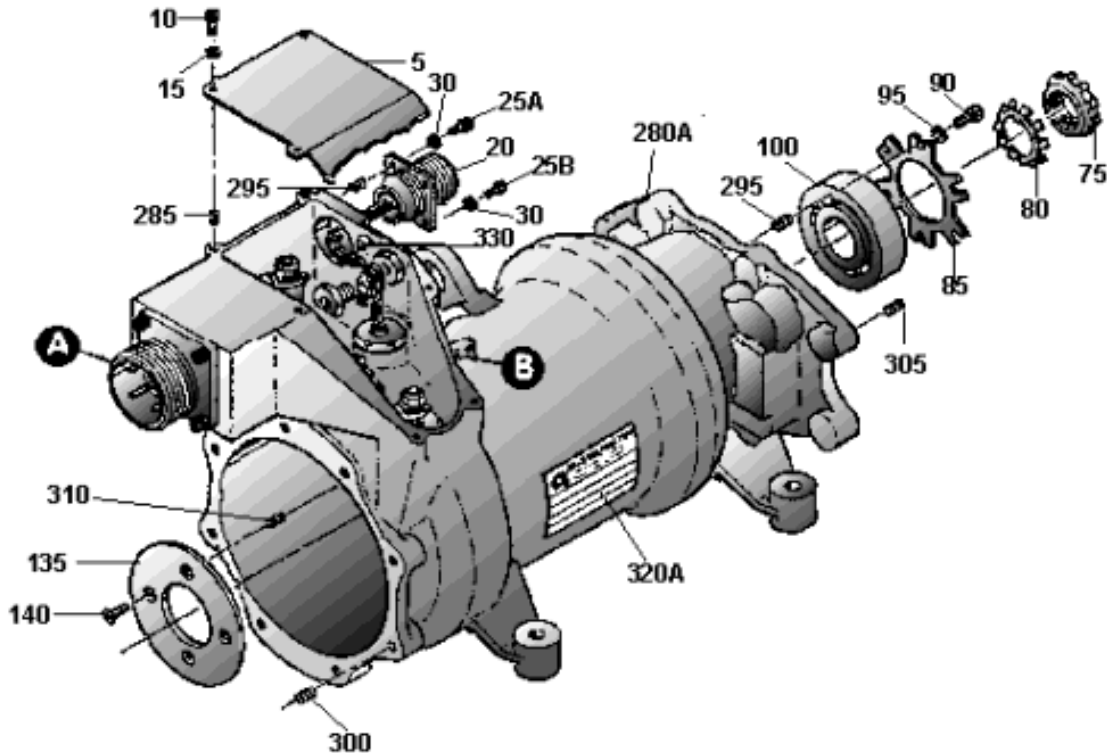

The graphic shown above is typical of those ALS displays when used during Depot (bench) maintenance (data acquisition / input). As the maintenance tech clicks on parts being services, a pop-up displays numeric data and verifies quantities of each piece part being Repaired, Replaced or Adjusted. When the user clicks OK, the data is posted to an Access database. It's that simple.

re - **Service Bulletins & Mods:** ALS does provide listings of alternate approved parts and does document the incorporation of service bulletins and equipment modification.

Data Input - Navigation bar

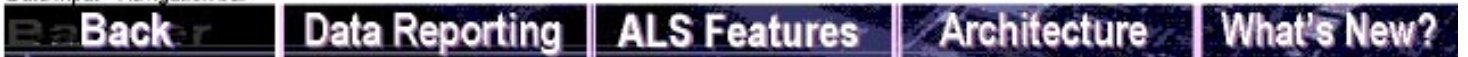

to learn more about the features of ALS or other products please email

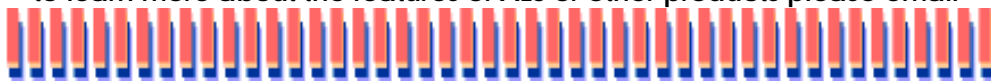

# ALS Data Analysis & Reporting

Beyond the graphical to database Line & Depot user interface that ensures consistent database precision, ALS provides aircraft component and fleet engineers with an assortment of seven (7) standard reports (as well as numerous optional and custom reports):

## ALS Database Reports

Standard, custom and other available

<ul style="list-style-type: none"> <li>* <b>Cost of Maintenance</b></li> <li>* <b>Installed Unit Age (Hrs by S/N)</b></li> <li>* <b>MTBUR &amp; MTBF (by Model &amp; Dash)</b></li> <li>* <b>Rogue Units (pareto by S/N)</b></li> </ul>	<ul style="list-style-type: none"> <li>* <b>Parts Usage</b></li> <li>* <b>Reason for Removal Analysis</b></li> <li>* <b>MTBUR &amp; MTBF (by A/C System)</b></li> <li><i>plus .. Custom Reports</i> (to your need)</li> </ul>
<ul style="list-style-type: none"> <li>MTBUR &amp; MTBF SubAssy &amp; P/Part</li> <li>Non-Confirmed Removal Analyses</li> <li>Optimum Overhaul Interval</li> </ul>	<ul style="list-style-type: none"> <li>Maintenance Factors Analysis</li> <li>Trend Analysis</li> <li>Weibull Analyses</li> </ul>

ALS allows full access to the MS\_Access97 database files to personnel with Engineering level or above user privilege (maintained by System Administrator). Thus, any level of research or analysis afforded by the content of your maintenance dataset is within your reach. ALS also exports data in common formats.



To view a sample ALS Report (test data only) please click on the icon to the right of this paragraph.

Data Reporting - Navigation bar

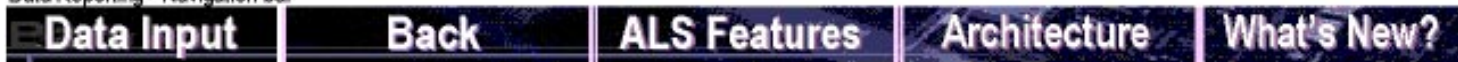

to learn more about the features of ALS or other products please email

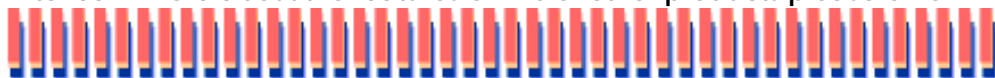

# ALS

## Design Features

Airline Software (ALS) is an **ODBC compatible** database program that can be integrated with various commercial airline purchasing - inventory and maintenance planning applications. ALS is the only program that collects and analyzes piece part (i.e. nut, bolt & washer etc.) level data, thus it provides analytical insight into subassembly and piece part reliability and failure modes & effects, the failure trends of these devices, and repair parts usage data that can be used to improve inventory management & costs.



As mentioned elsewhere on this site, ALS provides a number of salient benefits to its users, namely:



- Point & Click (graphical to database interface) data acquisition
- On-screen exploded view drawings (per CMM) - also a troubleshooting aid
- Seven (7) standard reports for some of the most common questions in the industry
- Five (4) levels of password protection limiting access based on privilege levels
- Bar Code interface (optional) is available if desired
- An assortment of customization utilities built-in for greater flexibility
- Comprehensive System Administration control of program operation & use

Features - Navigation bar



to learn more about the features of ALS or other products please email

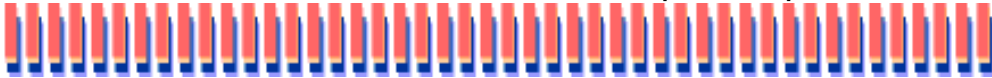

# ALS *Design Architecture*

**Modular Design & Configurable Flexibility** are built into ALS from the ground up. Included in the product-line are the Professional model, Point & Click, a select group of existing component modules (containing the graphical - database details of the unit), and a Universal Component Module (UCM).

The **UCM is a fast and inexpensive** alternative for airlines desiring to use ALS on several hundred unique aircraft components (equipment types / models). The UCM provides the same operability as the popular point & click (graphical to database) modules but uses tables instead of images to get the job done.



**ALS  
PROFESSIONAL**

**Includes:**

- Data Entry (Line/Intermediate/Depot)
- Network Access Package
- Engineering Tools
- Standard Reports
- System Administration



**ALS  
POINT & CLICK**  
Maintenance Data Acquisition Software

**Includes:**

- Data Entry (Line/Intermediate/Depot)
- Point & Click modules or UCM
- Network Access Package

Architecture - Navigation bar



to learn more about the features of ALS or other products please email

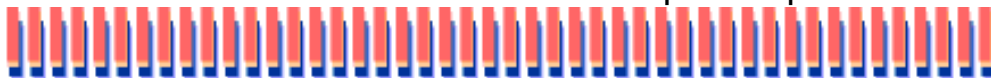



All new product walk throughs in flash coming soon.

What's New (announcements) - Navigation bar



to learn more about the features of ALS or other products please email

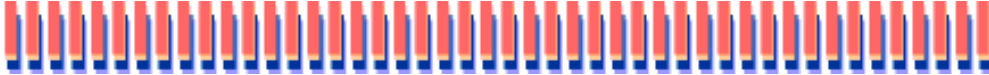

# System Safety Assessment (SSA)

The System Safety Assessment is the final part of the *complete Safety Assessment Process* which establishes aircraft component (equipment) safety objectives and demonstrates compliance with FAR/JAA 25.1309 and other safety related requirements. The *complete Safety Assessment Process* begins with a functional hazard assessment (FHA), is normally followed by a qualitative preliminary system safety assessment (PSSA) and ends with the quantitative SSA.

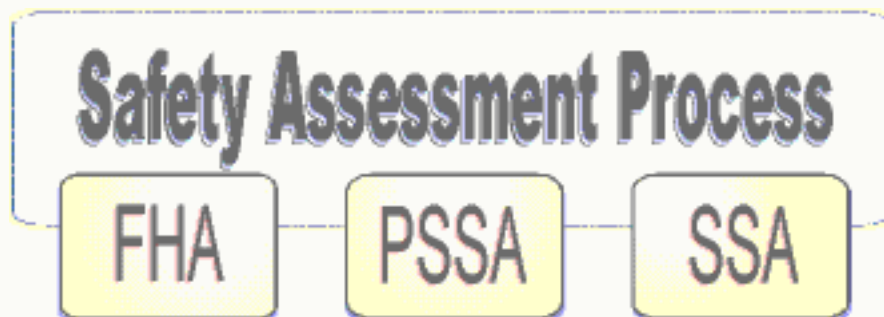

Simply put, the SSA is a systematic, comprehensive evaluation of your equipment, as implemented on-aircraft, to show that the safety objectives from the FHA have been met. In more detail, the SSA is usually based on PSSA analyses and uses quantitative results from Failure Mode and Effects Analyses and/or Summary (FMEA and/or FMES) in support of event driven fault tree analyses (FTA) to show that the probability of the functional hazard (or, fault condition) occurring during flight is less than the maximum value established as the safety objective (in the FHA).

[Click here to return!](#)

# Failure Mode & Effects Analysis (FMEA)

An **FMEA** is a systematic, bottom-up way of identifying the failure modes of a system, item or function and determining the effects of each on the next higher level (or assembly). Normally considered an integral part of the preliminary and critical design efforts, the FMEA can also be used to compile a failure mode and effects summary (FMES) when evaluating inputs for the next higher level FMEA(s). When required, the FMES provides groupings of single failure modes which produce the same failure effects, i.e. for each unique failure effect, a list of the single failure modes that could cause its occurrence is shown.

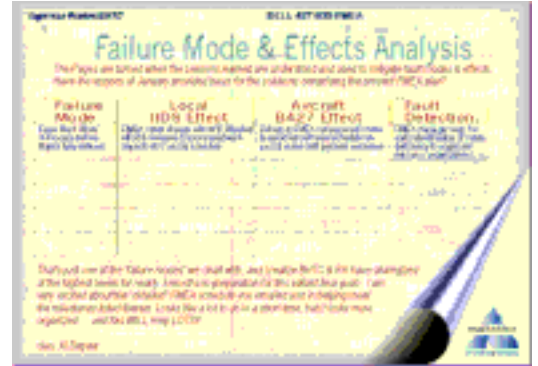

The **FMEA** can be performed at any level. Thus, to avoid costly revisions and delays in the completion of the report, the scope of the requirement should be verified with the user requesting it before the work is started.

## Commercial Programs:

In 1996, **SAE ARP4761** established the current guidelines for FMEA and many other analyses performed as part of the System Safety Assessment Process used to establish safety objectives and demonstrate compliance with **FAR/JAA 25.1309** and other Civil safety requirements.

## Military Programs:

**MIL-STD-1629** continues to be widely used as the guiding specification(s) for FMEA / FMECA. Moreover, where Military System Safety studies are required, **MIL-STD-882** is often used.

... for more [Info](#):

SAE International  
 400 North 7th Street  
 Warrendale, PA 15090  
 Mail Code  
 Wdmaster@hib.sae.org



Click on logo to return!

[please close-out this Window when done](#)



# Reliability Engineering

There are many accepted standards for determining piece part level failure rates in aerospace equipment. The most common are MIL-STD-217F Notice 2, BellCore and Manufacturer's experience.

## Failure Rate Predictions:

Click on logo to return!

When one thinks of reliability engineering, the term that predominantly comes to mind is the "reliability prediction", or more accurately the failure rate prediction. This is perhaps the basic building block of all developmental analysis, e.g. failure mode & effects analysis, fault tree analysis, risk assessment, availability and probability of failure, etc.

Parnassus provides its clientel with a reliable out-source for reliability predictions using most standard methods and can produce its reports in all formats. Our database systems allow us to output reports with total flexibility in field content and report format, and our expertise assures your predictions will be delivered in an accurate, timely and professional manner.

PL Porter Company 30 August, 1999		GEN-3 Motor Drive (Motherboard) PIECE PART RELIABILITY PREDICTION						Rel Prediction Coefficients										Page 1 File name: Gen3RelSample.xls Worksheet name: MtrDrv
Part No	Ref Des	Description	Qty	Manf Part	Manf	Failure	Failure											
								Total FR	LP(ea)	Lb	PICV	PIQ	PIE	FISR		D/Cyc	Qty	
CC030ER3	C24, C25	CAP 30PF 50V RADIAL +/- 10%	2	CCP300J50V	MERITEK	0.0034	2.62E-02	0.0039	0.56	3	4						2	
CC210ER3	C60	CAP .001MF 50V MONO RAD 0.1	1	8462228	FUTURE ACT	0.0039	3.74E-02	0.0039	0.8	3	4						1	
CC310FR1	C22, C23	CAP .01MF 100V MONO RAD 0.2CC	2	RD16R103K101	MERITEK	0.1039	6.19E-02	0.0039	1.11	3	4						2	
CC410ER5	Various	.1MF 50V MONO FORM LD 20C	21	RD162U104M500	MERITEK	1.2776	8.08E-02	0.0039	1.3	3	4						21	
CG610DR3	C8, C10	CAP 10MF 35V RADIAL TANTALUM	2	TAN1035EDTK(A)	EW ELECT	0.0137	8.89E-03	0.0085	1.32	1	4	0.2					2	
CG50FRD-SUB	P1, P2	CONN 50 PIN FEMALE D-SUB	2	17DD-50SC	NEWARK	0.0504	2.52E-02	0.0005	1	4.2	12						2	
CD7PHL32	JP1	CONN HEADER 7 PIN LOCKING	1	26-604-070	MOLEX	0.0123	1.20E-02	0.0005	1	2	12						1	
CO1843M04	Y1	CRYSTAL 1.843200 MHz HC-4	1	8810451	FUTURE ACT	0.1500	1.50E-01	0.013	1	12							1	
DB2A400V2	M-DB1	BRIDGE RECTIFIER 2A 400V SQUAR	1	KBP204	TAS ELEC	0.0116	1.16E-02	0.003	1	0.05	1	5.5	13				1	
DB25A600VF	M-DB1	BRIDGE RECTIFIER 25A 600V FLAT	1	D25X860	HV COMP	0.0116	1.16E-02	0.003	1	0.05	1	5.5	13				4	
DLH01R02	M-DB	LED RED T 1 3/4 H/INT	1	AM-53HT	ADVANCED	0.0087	8.10E-03	0.0023	1.6			5.5	4				1	
DR01A400F2	D1, D2, D12, D13	DIODE 1A 400V FAST REC PLASTIC	4	1N4936	TAS ELEC	0.0154	3.88E-03	0.001	1	0.05	1	5.5	13				4	
DS1N4148	D5	SIGNAL DIODE 100MA 100V	1	D10N4148T	EW ELECT	0.0147	1.47E-02	0.0038	1	0.05	1	5.5	13				1	
DZ106V5W1	M-D1, D4	ZENER DIODE 6.0V 0.5W GLASS	2	1N5238B	FUTURE ACT	0.1359	9.30E-02	0.013	1	1	5.5	13					2	
DZ110V01W2	M-D7, D9	ZENER DIODE 10V 1W PLASTIC	2	1N4740AT	EW ELECT	0.1359	9.30E-02	0.013	1	1	5.5	13					2	
DZ168V600U	M-DB10/11	TVS 68V 600W UNIDIRECTIONAL	3	2749927	FUTURE ACT	0.2769	9.30E-02	0.013	1	1	5.5	13					3	
FX050X05.00	F1, F2	FUSE MOV 50V 5A RADIAL	2	2129393	FUTURE ACT	0.183	6.00E-02	0.01	9								2	
FX080X00.20	F11 - F14	FUSE MOV 80V 0.2A RADIAL	4	5469760	FUTURE ACT	0.183	6.00E-02	0.01	9								4	
FX080X01.80	F3, F4, F7, F10	FUSE MOV 80V 1.8A RADIAL	4	5457763	FUTURE ACT	0.183	6.00E-02	0.01	9								4	
IC8A1013CP	U6A6	IC DUAL PRECIN OP AMP LO OPSET	1	LT1013CN6	ARRAW ELEC	0.0572	3.79E-02										1	
IC8A393	U7	INT CIRC DUAL VOLT COMP ARATOR	1	4074376	FUTURE ACT	0.0686	8.86E-02										1	
ICM52891A	U2, U9	IC 8-BIT SERIAL LATCH SRCE DAK	2	4713277	FUTURE ACT	0.0686	8.86E-02										2	
ICM587C660	U4	IC 8-BIT UC OTP & PLCC 8051	1	3020808	FUTURE ACT	0.0686	8.86E-02										1	
RB1100.2F	R32, R33	RESISTOR CARB 1K OHM 1/4W 1%	2	RMF RN55C-1KFT	EW ELECT	0.0480	2.40E-02	0.0012	1	5	4						2	
RB1107.2F	R19, R20	RES METAL FILM	2	RMF RN55C-1X07KFT	EW ELECT	0.0480	2.40E-02	0.0012	1	5	4						2	
RB1154.2F	R21, R22	RES METAL FILM	2	RMF RN55C-1X54KFT	EW ELECT	0.0480	2.40E-02	0.0012	1	5	4						2	
RB1165.2F	R1, R2	RES METAL FILM 165K 1/4W 1%	2	RMF RN55C-1X65KFT	EW ELECT	0.0480	2.40E-02	0.0012	1	5	4						2	
RB267.2F	R7, R8	RES METAL FILM	2	RMF RN55D-267FT	EW ELECT	0.0480	2.40E-02	0.0012	1	5	4						2	
RB316.2F	R9, R10	RES METAL FILM	2	RMF RN55C-316FT	EW ELECT	0.0480	2.40E-02	0.0012	1	5	4						2	
RB383.2F	R11, R12	RES METAL FILM	2	RMF RN55D-383FT	EW ELECT	0.0480	2.40E-02	0.0012	1	5	4						2	
RB475.2F	R13, R14	RES METAL FILM	2	RMF RN55C-475FT	EW ELECT	0.0480	2.40E-02	0.0012	1	5	4						2	
RB604.2F	R15, R16	RES METAL FILM	2	RMF RN55C-604FT	EW ELECT	0.0480	2.40E-02	0.0012	1	5	4						2	
RB768.2F	R17, R18	RES METAL FILM	2	RMF RN55D-768FT	EW ELECT	0.0480	2.40E-02	0.0012	1	5	4						2	
RD2100.1K	R36, R37	RES METOX 1K OHM 1W 10%	2	4341707	FUTURE ACT	0.0063	1.17E-03	0.00072	1.1	1	4						2	
RN3100.10GS	RP1, RP2	RES NETWORK 10K OHM COMMON	2	RKLB3103G	NATIONAL EL	0.0220	1.10E-02	0.00006	3	4	1.91	8					2	
RY1C1203	K1 thru K14	RELAY SPDT 12V 20A 0.3MM GAP	14	JIM-12V	MASTER DIST	0.0227	1.62E-03	0.006	0.05	1	0.1	6	3	15	0.2		14	
SQM18P05	Q5, Q6	MOSFET 50V -18A 0.14 OM TO220	2	9863267	FUTURE ACT	8.040	1.4E+00	0.012	1	4		5.5	13	0.2			2	
SQM27N10	Q3, Q4	MOSFET 100V 27A 0.052 OM TO220	2	8599243	FUTURE ACT	1.3739	8.89E-01	0.012	1	4		5.5	13	0.2			2	
SR2E4N804	Q1, Q2	TRANSISTOR 40V 0.2A NPN TO92	2	8599244	FUTURE ACT	0.0087	4.07E-03	0.00074	1	0.7	1	0.11	5.5	13			2	
SU035V500A2	RV1, RV2, RV3	MOV 35VAC 500A RADIAL	3	Z10L660	ITAL ELEC	18.7469	6.29E+00	0.093	1	1.4	1	2	3	8	1		3	
SU017V500A2	RV4	MOV 17VAC 500A RADIAL	1	Z19L270	ITAL ELEC	8.1309	8.19E+00	0.073	1	1.4	1.05	2	3	8	1		1	
SV+05.75P03LD	U5	VOLT REG +5V 750MA RESET LO-DP	1	6769285	FUTURE ACT	0.0310	3.10E-02										1	
SV+1201P03LD	U1	VOLT REG +12V 1A LO-DROP TO220	1	628617	FUTURE ACT	0.0310	3.10E-02										1	
SWB051A1	ST (INDY)	SWITCH SPST ROCKER DP	1	76R98056	CAL SWITCH	0.3400	3.40E-01	0.034	1	1							1	
<b>Motor Drive (Motherboard) Predicted Failure Rate:</b>							<b>36.680</b>	<b>FPMH</b>										
							<b>27,263</b>	<b>Mean Time Between Failures (Predicted)</b>										



### Parnassus Database Systems

PMB-482, 2510-G Las Posas Rd., Camarillo, CA. 93010 (805) 552-9552 fax (805) 552-9553 email: parnassu@ix.netcom.com

to learn more about the various reliability prediction services Parnassus offers please call or email.



## Reliability Engineering

To learn more about aerospace reliability topics or the services Parnassus offers please [email questions & comments](#)

---

### System Level - Modeling and

### Allocations

*(the following are a list of topics that will soon be covered by our site.)*

- Reliability Block Diagrams
- Failure Rate Allocation
- Reliability Modeling of complex-redundant & fault tolerant systems
- Logistics and Mission reliability predictions
- Fault Tree Analysis (FTA)
- Weibull Analysis

Click on logo ot return!



Click on Logo to return!

**"How much is your product really costing me?" --**  
**After the sale, what does it really cost the airlines to own your product?**

Airline operators are interested in how much it's going to cost them to own and operate your equipment over a 20-year life. Several factors determine the actual cost of ownership (a.k.a. power by the hour, maintenance operating costs, etc.) and these can be determined statistically through the proper acquisition and analysis of in-field performance and maintenance data. Similar costs can be acquired and analyzed for your competitor's equipment as well. As shown in the following Cost of Maintenance report, the actual costs of operating two similar LRUs manufactured by different vendors can vary by millions of dollars over a 20-year life cycle. How does your equipment stack-up?

operating two similar LRUs manufactured by different vendors can vary by millions of dollars over a 20-year life cycle. How does your equipment stack-up?

Your Company Logo here  
 Customer Service Organization

**Annual Cost of Maintenance**  
 Cost of operating & maintenance

Reliability Cost Center	Competitor's Cost	Your Product's Cost
<b>B737-XXX Fleet Information:</b>		
1. AIRCRAFT FLEET SIZE	50	50
2. AVERAGE FLEET AGE (YEARS)	7.89	7.89
3. LINES PER AIRCRAFT	2	2
4. ANNUAL LRU HOURS	287,985	287,985
<b>Annual Line Maintenance Cost:</b>		
5. MEAN TIME BETWEEN FAILURES (MTBF)	7,000	16,565
6. UNSCHEDULED REMOVAL RATE (URR)	0.1429	0.0585
7. ANNUAL UNSCHEDULED REMOVALS	41.14	16.85
8. ANNUAL LINE MAINTENANCE LABOR (AT \$33/HR. & 1.5 HRS/LRU)	\$2,169	\$890
<b>Annual Cost of Delays:</b>		
9. % OF LRU'S RESULTING IN FLIGHT (FL) DELAY	32.67%	32.67%
10. ANNUAL LRU'S RESULTING IN FL DELAY	13.41	5.50
11. AVERAGE COST OF FL DELAY	\$3,948	\$3,948
12. ANNUAL COST OF FL DELAYS DUE TO LRU FAILURE	\$52,956	\$21,309
<b>Annual Cost of Cancellations:</b>		
13. % OF LRU'S RESULTING IN FL CANCELLATION	13.37%	13.37%
14. ANNUAL LRU'S RESULTING IN FL CANCELLATION	5.47	2.22
15. AVERAGE COST OF FL CANCELLATION	\$5,783	\$5,783
16. ANNUAL COST OF FL CANCELLATIONS DUE TO LRU FAILURE	\$31,681	\$12,849
<b>Annual Maintenance Cost:</b>		
17. ANNUAL FUEL BURN REPAIRS AND OVERHAULS	41,174	16,565
18. LABOR & MATERIAL COST PER SHOP VISIT	\$3,280	\$3,420
19. SHOPPING COSTS (10% SHOP)	\$331	\$362
20. ANNUAL MAINTENANCE COST	\$134,972	\$57,383
<b>Annual Fuel Burn Cost:</b>		
21. WEIGHT OF AIRCRAFT IN POUNDS	32,771	31,111
22. COST OF FUEL BURNED PER 1,000 LBS.	15.40	15.40
23. ANNUAL FUEL BURN COST DUE TO LRU WL (W/AVG. SFC)	\$51,388	\$36,891
<b>Annual Inventory and Scrap Costs:</b>		
24. INVENTORY OF SPARE LRUS	-	-
25. COST OF A SPARE LRU **	\$28,660	\$17,280
26. INVENTORY CARRYING COST AT 12%	\$6,239	\$4,147
27. SCRAP COST	\$0.988	\$1,280
28. ANNUAL INVENTORY AND SCRAP COST	\$35,887	\$21,427
29. TOTAL ANNUAL COST OF MAINTENANCE	\$339,458	\$170,976

**Net Present Value Prediction**  
 based on 4% inflation

YEAR OF OWNERSHIP	Economic Factor	Competitor's Costs	Your Product's Costs	Annual Savings	Total Savings
1	1.000	\$339,458	\$170,976	\$168,482	\$168,482
2	1.040	\$353,036	\$177,815	\$175,221	\$343,703
3	1.082	\$367,158	\$184,828	\$182,330	\$526,033
4	1.125	\$381,844	\$192,323	\$189,519	\$715,553
5	1.170	\$397,118	\$200,018	\$197,100	\$912,653
6	1.217	\$413,003	\$208,018	\$204,984	\$1,117,637
7	1.265	\$429,523	\$216,339	\$213,183	\$1,330,420
8	1.315	\$446,704	\$224,993	\$221,711	\$1,552,431
9	1.368	\$464,572	\$233,992	\$230,579	\$1,783,011
10	1.423	\$483,155	\$243,352	\$239,802	\$2,022,813
11	1.480	\$502,461	\$253,086	\$249,395	\$2,272,207
12	1.539	\$522,580	\$263,210	\$259,370	\$2,531,578
13	1.601	\$543,483	\$273,738	\$269,745	\$2,801,323
14	1.665	\$565,221	\$284,688	\$280,530	\$3,081,858
15	1.732	\$587,831	\$296,075	\$291,756	\$3,373,614
16	1.801	\$611,340	\$307,918	\$303,427	\$3,677,041
17	1.873	\$635,788	\$320,230	\$315,564	\$3,992,804
18	1.946	\$661,230	\$333,044	\$328,186	\$4,320,790
19	2.022	\$687,680	\$346,366	\$341,314	\$4,662,104
20	2.101	\$715,167	\$360,221	\$354,966	\$5,017,070
21	2.181	\$743,704	\$374,629	\$369,165	\$5,386,430
22	2.279	\$773,348	\$389,615	\$383,931	\$5,770,166
23	2.370	\$804,088	\$405,199	\$399,285	\$6,168,450
24	2.465	\$835,967	\$421,407	\$415,260	\$6,584,715
25	2.563	\$870,134	\$438,263	\$431,871	\$7,016,686

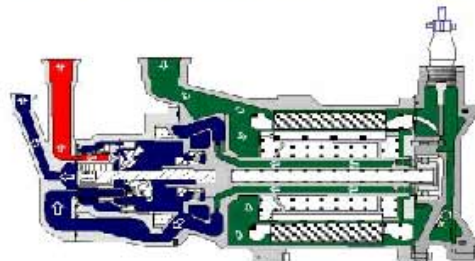

Parnassus Database Systems

PMB-482, 2510-G Las Posas Rd. Camarillo, CA. 93010 (805) 552-9552 Fax: (805) 552-9553 email: parnassu@ix.netcom.com

Parnassus provides Independent 3rd Party Reliability Reports your Marketing department can distribute to potential customers (to justify call-outs of your product) as well as your long time loyal customers to demonstrate that reliability and cost of ownership are among the top concerns of your company.

to learn more about independent 3rd party reports and other analysis services please call or email.